

kalon

CARAVAN DIVAN &  
CONVERSION  
KIT ASSEMBLY  
INSTRUCTIONS

---

---

*INSTRUCTIONS  
POUR LE MONTAGE  
DU DIVAN  
CARAVAN ET KIT DE  
TRANSFORMATION*

Model N°: Caravan Divan 043 & Caravan Conversion Kit 042 | KALON STUDIOS

[www.kalonstudios.com](http://www.kalonstudios.com) | [studio@kalonstudios.com](mailto:studio@kalonstudios.com)

P.O. Box 292612 | Los Angeles | CA 90029 | 866.514.2034



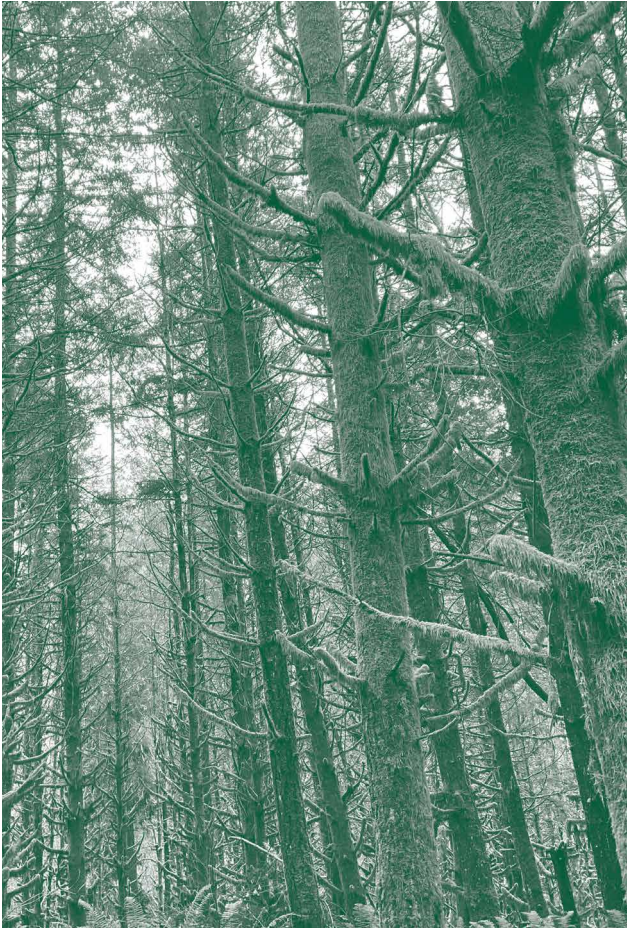

## ENTIRELY ORIGINAL DESIGN FOR A SUSTAINABLE CULTURE

Made with uncompromising craftsmanship by traditional woodworkers in the USA from 100% sustainably-harvested, solid, domestic wood, the Caravan Collection is a celebration of craft and contemporary American woodworking.

The unique character of the natural material is an integral part of the design that will only improve with age and use.

As with all of our pieces, we used the most sustainable materials and methods available. This collection is manufactured in the United States, upholding the long-standing regional tradition of furniture making and the craftspeople who are a part of it. Designed to be as socially and environmentally responsible as it is beautiful, each piece is built to last for generations of use.

## MAINTENANCE, CLEANING AND STORAGE

Please take care to periodically check the crib/toddler bed to ensure that it is properly assembled and that no parts have come loose. Verify that the crib toddler bed parts remain fit snugly against one another and tighten hardware if needed. Clean with a rag dampened with warm water. Do not use soap or harsh chemicals as they will remove the natural, oil-wax finish.

Maintain finish with wood oil of your choice or contact [studio@kalonstudios.com](mailto:studio@kalonstudios.com) for recommendations.

For best storage, repack crib/toddler bed in original packaging and/or store in a dry area, upright and flat.

Do not allow to bend.

**Keep instructions in pouch for future use.**

---

---

## *ENTRETIEN, NETTOYAGE ET RANGEMENT*

*Veillez inspecter régulièrement le meuble, s'assurer que les pièces soient bien assemblées et que les composantes ne se soient pas desserrées. Au besoin, utilisez un tournevis pour resserrer les pièces.*

*Nettoyez les surfaces à l'aide d'un chamois imprégné d'eau tiède. Veillez éviter l'utilisation de savon ou de nettoyeurs chimiques qui risqueraient d'enlever le fini de cire et d'huile naturelle. Vous pouvez redonner un lustre au fini en appliquant une huile naturelle pour bois de votre choix ou nous contacter par courriel à [studio@kalonstudios.com](mailto:studio@kalonstudios.com) pour des recommandations.*

*Pour optimiser l'entreposage, vous pouvez démonter et remettre le meuble dans son emballage original et l'entreposer dans un environnement sec en position verticale ou horizontale afin d'éviter toute déformation.*

***Veillez conserver les instructions dans la pochette pour la prochaine utilisation.***

## PIECES INCLUDED / PIÈCES INCLUSES

Refer to pouch for true to life diagram of hardware.



..... Backrest ( x1 )  
..... Panneau d'appui ( x1 )



..... Side Panel ( x2 )  
..... Panneau latéral ( x2 )



..... Side Panel Foot ( x2 )  
..... Panneau inférieur latéral ( x2 )



..... End Panel ( x2 )  
..... Panneau d'extrémité ( x2 )



..... End Panel Foot ( x2 )  
..... Panneau inférieur d'extrémité ( x2 )



..... Mattress Support ( x1 )  
..... Support de matelas ( x1 )



..... A1 (x10)



..... C (x4)



..... H (x4)



..... A2 (x10)



..... E (x12)



..... I (x4)



..... B (x10)



..... G (x4)



..... Allen Key  
(x1 Lg. x1 Sm)

*Philips head screwdriver required for assembly. Tournevis cruciforme requis pour le montage.  
More fun when done with two people. Even better with an electric screwdriver.*

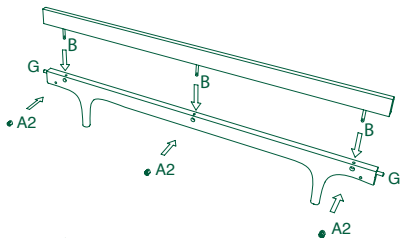
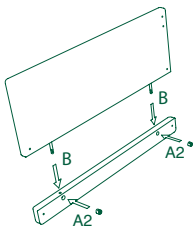

DETAIL 1 / DÉTAIL 1

DETAIL / DÉTAIL 2

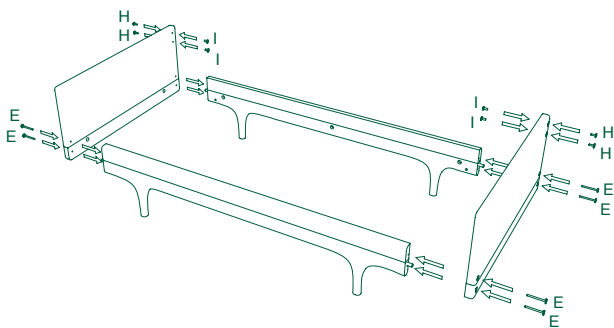
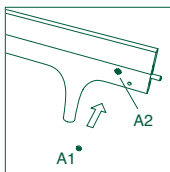
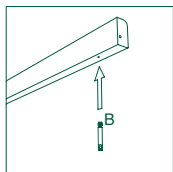

## STEP 1

- Insert parts G into available holes at end of Side Panel Feet.
- Screw parts B into holes along bottom edge of the Side and End Panels. (Detail 1)
- Insert parts A2 into large holes along inner face of all panel feet.
- Lower the Side and End Panels onto panel feet by sliding parts B through holes along upper edge of all panel feet and into holes in parts A2.
- Use the small Allen Key to screw parts A1 into parts A2. (Detail 2)

### *ETAPE 1*

- *Insérez les pièces G dans les ouvertures prévues sur le panneau d'extrémité.*
  - *Vissez les pièces B dans les ouvertures prévues le long des panneaux latéraux et des panneaux d'extrémité. (Détail 1)*
  - *Insérez les pièces A2 dans les ouvertures prévues sur le côté intérieur de l'ensemble des panneaux inférieurs.*
  - *Assemblez les panneaux supérieurs avec les panneaux inférieurs en insérant les pièces B dans l'ouverture correspondante.*
  - *Avec la petite clé Allen, fixer les pièces A1 dans l'ouverture correspondante dans les pièces A2. (Détail 2)*
- 
- 

## STEP 2

- Insert parts E through holes on outer side of End Panels, then into holes on edge of Side Panels and Side Panel Feet. Use the large Allen Key to tighten.
- (If using backrest skip this step) Insert parts H and I into holes at top corner of end panels. Use the large Allen Key to tighten.

### *ETAPE 2*

- *Insérez les pièces E dans les ouvertures prévues sur le côté extérieur des panneaux d'extrémité, et dans les ouvertures prévues sur les panneaux latéraux. À l'aide de la grande clé Allen, fixez les pièces E.*
- *(Si vous utilisez le panneau d'appui, passez à l'étape suivante) Insérez les pièces H et I dans les ouvertures prévues sur le côté extérieur des panneaux d'extrémité. Avec la grande clé Allen, fixez les pièces H et I.*



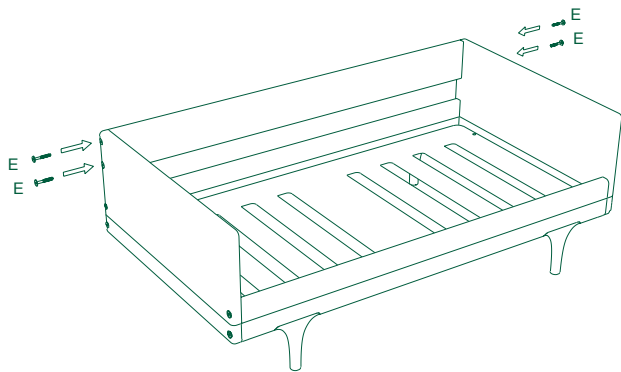
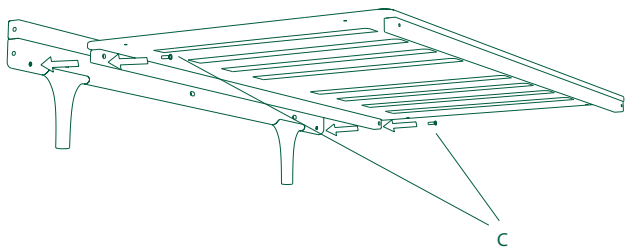

## STEP 3

- Insert parts C through holes at bottom of Mattress Support and into holes on Side Panel Feet.
- Use a philips head screwdriver to tighten parts C.

### *ETAPE 3*

- *Fixez le support de matelas sur les panneaux latéraux en insérant les pièces C dans les ouvertures prévues.*
- *Utilisez un tournevis cruciforme pour fixer les pièces C.*

---

---

## STEP 4 attaching backrest

- When converting the Divan to be used with backrest remove parts H and I.
- Insert parts E through holes on outer side of End Panels then into holes on edge of Backrest.
- Use the large Allen Key to tighten parts E.

### *ETAPE 4 pour fixer le panneau d'appui*

- Si elles sont attachées ensemble, séparez les pièces H et I.
- Insérez les pièces E dans les ouvertures prévues sur le côté extérieur des panneaux d'extrémité, et dans l'ouverture correspondante sur le panneau d'appui.
- Utilisez la grande clé Allen pour fixer les pièces E.

## NOTES

- According to CPSC regulations Toddler Beds are not intended for use for children younger than 15 months or more than 50lbs.
- Not to be used as toddler bed beyond the 50lbs limit.
- Weight limit of Divan is 200lbs.
- Intended for use with full-size crib mattress having minimum dimensions of 51 5/8 in. (1310 mm) in length and 27 1/4 in. (690 mm) in width and 6 in. (150 mm) in thickness.
- **Conversion Kit does not include a base or mattress support, includes backrest, upper side and end panels only.**

---

---

## NOTES

- *Le meuble n'est pas destiné à des enfants de moins de 15 mois ou pesant plus de 23kg ou 50lbs.*
- *Le meuble requiert l'utilisation d'un matelas ayant les dimensions minimales de 51 5/8 pouces (1310 mm) de long, 27 1/4 pouces (690 mm) de large et 6 pouces (150 mm) d'épaisseur.*
- *Le Kit de Transformation inclut le panneau d'appui, les panneaux supérieurs et n'inclut pas de base ou de support de matelas.*



**WARNING:** Read all instructions before assembling toddler bed. KEEP INSTRUCTIONS FOR FUTURE USE.

• Failure to follow these warnings and the assembly instructions could result in serious injury or death. • **INFANTS HAVE DIED IN TODDLER BEDS FROM ENTRAPMENT.** Openings in and between bed parts can entrap head and neck of small child. • **NEVER** use bed with children younger than 15 months. • **ALWAYS** follow assembly instructions. • **NEVER** place bed near windows where cords from blinds or drapes may strangle a child. • **NEVER** suspend strings over bed. • **NEVER** place items with string, cord, or ribbon, such as hood strings or pacifier cords, around a child's next. These items may catch on bed parts. • To avoid dangerous gaps, any mattress used in this bed shall be a full-size crib mattress at least 131 cm in length, 69 cm in width, and 15 cm in thickness. • Before each usage or assembly, inspect toddler bed for damaged hardware, loose joints, missing parts or sharp edges. • **DO NOT** use toddler bed if any parts are missing or broken. Ask your dealer or write to Kalon Studios for replacement parts and instructional literature if needed. **DO NOT** substitute parts. • Never use plastic shipping bags or other plastic film as mattress covers because they can cause suffocation. • **DO NOT** use a water mattress with this toddler bed.