

kalon

INSTRUCTIONAL LITERATURE CHANGING TRAY

Model N°: Changing Tray O44 | KALON STUDIOS

www.kalonstudios.com | studio@kalonstudios.com

P.O. Box 421462 | Los Angeles | CA 90042 | 866.514.2034

ENTIRELY ORIGINAL. DESIGN FOR A SUSTAINABLE CULTURE.

Made with uncompromising craftsmanship by traditional woodworkers in the USA from 100% sustainably-harvested, solid, domestic wood, the Changing Tray is a celebration of craft and contemporary American woodworking.

The unique character of the natural material is an integral part of the design that will only improve with age and use.

As with all of our pieces, we used the most sustainable materials and methods available. This piece is manufactured in America, upholding the long-standing regional tradition of furniture making and the craftspeople who are a part of it. Designed to be as socially and environmentally responsible as it is beautiful, this piece was built to last for generations of use.

www.kalonstudios.com | www.kalonstudios.de

GENERAL INSTRUCTIONS

Read all instructions before use. **Keep instructions for future use.**

- Do not use Changing Tray if it is damaged or broken.
- Intended for use with a contoured changing pad (pad not included) 16" w x 33" l x 4" h.
- This product is not intended to be used as a changing table without a contoured changing pad. Use of the product without this may result in death or serious injury to your child from falling. Follow all instructions on attaching and using the changing pad.
- Not to be used beyond the maximum weight limit of 30lbs.

Maintenance + Cleaning Please take care to periodically check to ensure that no parts have come loose. Tighten hardware if necessary. Clean with a rag dampened with warm water. Do not use soap or harsh chemicals as they will remove the natural, oil-wax finish.

Attaching Hardware use the supplied mounting plates and screws to attach the Changing Tray to your Kalon dresser or other supporting surface. It is recommended that the plates are mounted to the rear of the Changing Tray. See detail below.

Enjoy!

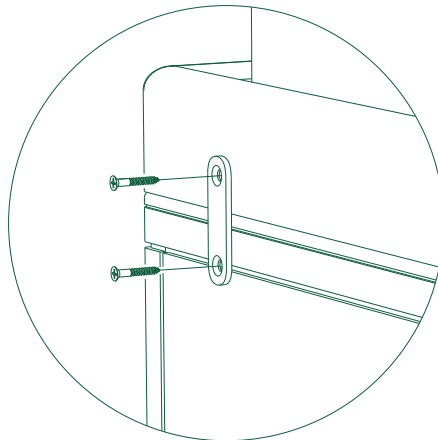

Mounting Plate
x2



Screw
x4



⚠️ WARNING

FALL HAZARD: Children have suffered serious injuries after falling from changing tables. Falls can happen quickly.

- **STAY** in arm's reach of your child.
- **ALWAYS** secure this unit to the support surface using the mounting brackets and hardware provided. See instructions. The support surface used should be level, stable and structurally sound with minimum surface dimensions of 920mm x 480mm.

