



kalon

CATALOG
2024

Contents

New American Modernism	3
Our Collections	4
Element Collection	5
Simple Collection	7
Highland Collection	10
Bough Collection	12
Isometric Collection	14
Cube + Void Series	16
Rugosa Collection	18
Kalon x Reath Rugosa Collection	21
Material Studies	23
No. 5 Series	25
No. 6 Series	27
Caravan Collection	29
Echo Collection	32
Io Collection	34
Stump & Trunk Collection	36
Tableware Collection	38
Beyond Beauty	41
The ways we work	42



New American Modernism Design for a Sustainable Culture

Stemming from a belief in the simple beauty and emotive power of everyday objects, Kalon seeks to deepen our relationship and reverence for the things we live with. Kalon's work maintains a strong point of view informed by American furniture traditions and modernist design, with a focus on elemental forms, natural materials, and versatility. The studio prides itself on its intense attention to materiality, which is at the core of each of their designs, as is an obsession with integrity. With a commitment to ecologically-conscious, regional production, Kalon partners with small teams of highly skilled, fairly paid craftspeople and uses timber sourced from sustainably managed forests and the highest quality natural finishes and materials. By balancing traditional craft modalities with high-tech precision manufacturing and modern forms, Kalon invites a new chapter of contemporary, sustainable design.

Kalon was founded in 2007 by Michael Simmering and Johannes Pauwen and is currently based out of Los Angeles, California.





Our Collections

Every Kalon collection has sprung from our own lives — they are the pieces we need, desire, and love. Elevated nursery designs that refuse to compromise, versatile dining pieces that seat those we love, living room staples that invite conversation: Our collections reflect the ways we live... and hope to live, in our homes and the intimate gathering spaces beyond (libraries, hotels, restaurants, museums, work spaces, etc.).

The materials we work with are carefully selected for their unique qualities as well as their ability to grow more beautiful with use and age. We believe sustainability also has to do with how long we love a piece — how many lives it lives. We design with flexibility of use, durability, and timeless appeal in mind so that our work may effortlessly adapt to our customers' changing needs and tastes over the course of a lifetime.



Element Collection

A meditation on elemental purity. Pared-down and exacting. Furniture that utilizes the practicality and poetry of Aluminum.

Element Collection

Standard species: Douglas Fir
Finishes: Kalon Bare Finish
Other Materials: Brushed Aluminum

Estimated lead times and shipment: 8-10 weeks

The collection includes a bed and forthcoming case goods.

801-Q-F-A



801-K-F-A





Simple Collection

Modern purity of form and feelings of calm. Nodding to classic modernist aesthetics, made with solid oil-rubbed domestic hardwoods and accented with luminous machined brass.

Standard species: Ash / Black Walnut
 Finishes: Kalon Bare Finish or Natural Oil/Wax
 Standard Fabrics: Linen / Mohair / Leather
 Hardware: Solid Brass (Unlacquered)

Custom dimensions, species and COM available upon request.
 Estimated lead times and shipment: 8-10 weeks

Simple Collection

The collection includes a bed, 8-drawer dresser, 4-drawer dresser, tallboy, side table, upholstered bench and mirror.

801



801



802



803



804



805



806



807



Standard species: Ash / Black Walnut
 Finishes: Kalon Bare Finish or Natural Oil/Wax
 Standard Fabrics: Linen / Mohair / Leather
 Hardware: Solid Brass (Unlacquered)

Custom dimensions, species and COM available upon request.
 Estimated lead times and shipment: 8-10 weeks

Simple Collection

The collection includes a bed, 8-drawer dresser, 4-drawer dresser, tallboy, side table, upholstered bench and mirror.

801



801



802



803



804



805



806



807





Highland Collection

A nod to the rugged California landscape.
Proportions evoking substance and permanence.
An embrace of organic imperfection rendered in
smooth White Oak.

Standard species: White Oak
Finishes: Kalon Bare Finish
Standard Fabrics: Linen / Leather

Custom dimensions, species and COM available upon request.
Estimated lead times and shipment: 8-10 weeks

Highland Collection

The collection includes an extension table, a desk, chair and bench.

710



714



711



712





Bough Collection

A study of contrast and balance inspired by craft traditions. Airy proportions and solid hardwood construction punctuated by intricate concealed joinery.

Standard species: Ash / Black Walnut / White Oak
 Finishes: Kalon Bare Finish or Natural Oil/Wax
 Hardware: Blackened Steel

Custom dimensions, species and COM available upon request.
 Estimated lead times and shipment: 8-10 weeks

Bough Collection

The collection includes tables, benches and stools in various sizes.

701-ONE-A
 701-ONE-O



701-ONE-W



701-TWO-W
 701-TWO-O
 701-TWO-A



701R-W
 701R-O
 701R-A



702-TWO-W
 702-TWO-O
 702-TWO-A



702-ONE-W
 702-ONE-O
 702-ONE-A



703-W
 703-O
 703-A



703B-W
 703B-O
 703B-A





Isometric Collection

Our first collection. A standing ode to the practical and timeless beauty born from the craftsmanship of early American furniture design traditions.

Standard species: Ash / White Oak / Walnut
Finishes: Kalon Bare Finish or Natural Oil/Wax

Custom dimensions, species and COM available upon request.
Estimated lead times and shipment: TBD

Isometric Collection

The collection includes tables and benches in various sizes and a chair.

112-A-L
112-O-L
112-W-L



112-A-M
112-O-M
112-W-M



112-A-S
112-O-S
112-W-S



113-A-L
113-O-L
113-W-L



113-A-M
113-O-M
113-W-M



113-A-S
113-O-S
113-W-S



111-A



111-O
111-W





Cube + Void Series

Inviting artful composition through the interplay between form and negative space. Monumental and profoundly utilitarian forms that highlight scale and the inherent beauty of natural materials.

Standard species: White Oak
Finishes: Kalon Bare Finish

Custom dimensions, species and COM available upon request.
Estimated lead times and shipment: 8-10 weeks

Cube + Void Series

The series includes a bench, variations of a coffee/tea table and wooden cubes

902



903



904



900





Rugosa Collection

A love letter to the living room and lounging. An invitation to comfort and repose. Made from broad planks of domestic wood, bronzed glass, and plush Belgian linen-wrapped cushions.

Rugosa Collection

Standard species: Sugar Pine (US) / Nordic Pine (EU)
Ash / White Oak / Black Walnut
Finishes: Kalon Bare Finish or Natural Oil/Wax
Standard Fabrics: Linen / Mohair
Other Materials: Bronzed Glass
Custom dimensions, species and COM available upon request.
Estimated lead times and shipment: 8-10 weeks

The collection includes a sofa, armchair, day bed, coffee table, side table and bookshelf.

510



510



511



511



512



512



Rugosa Collection

Standard species: Sugar Pine (US) / Nordic Pine (EU)
 Ash / White Oak / Black Walnut
 Finishes: Kalon Bare Finish or Natural Oil/Wax
 Standard Fabrics: Linen / Mohair
 Other Materials: Bronzed Glass
 Custom dimensions, species and COM available upon request.
 Estimated lead times and shipment: 8-10 weeks

The collection includes a sofa, armchair, day bed, coffee table, side table and bookshelf.

514-D



514-H



514-X



514-R



514-O



515





Kalon x Reath Rugosa Collection

An exuberant take on our Rugosa collection, this collaboration blends the spirit of minimalism and creativity of pattern play.

Standard species: Sugar Pine (US) / Nordic Pine (EU)
Finishes: Kalon Bare Finish or Natural Oil/Wax
Standard Fabrics: Linen / Cotton / Wool

Kalon x Reath Rugosa Collection

Estimated lead times and shipment: 8-10 weeks

The collection includes a sofa, armchair and daybed.

KXR-510



KXR-510



KXR-512



KXR-512



KXR-511





Material Studies

An indoor-outdoor collection born from our Rugosa Collection and the first chapter in our Material Studies. Exploring the profound impact material choice has on design.

Standard materials: Powder-coated Aluminum
Finishes: Oxblood, Lapis, Lime White
Standard Fabrics: 100% Trevira
Other Materials: Bronzed Glass

Material Studies

Estimated lead times and shipment: 8-10 weeks

The collection includes an armchair, coffee table, side table and dining table.

512-A



514-A



513-A



517-A





No. 5 Series

Our most customizable seating collection. Inspired by mid-century design with a radical commitment to transparency, precision, and longevity.

Standard species: White Oak
Finishes: Kalon Bare Finish
Standard Fabrics: Wool

Custom dimensions, species and COM available upon request.
Estimated lead times and shipment: 8 - 12 weeks

No. 5 Series

The collection includes a chaise, sofa and sectional.

500



501



503

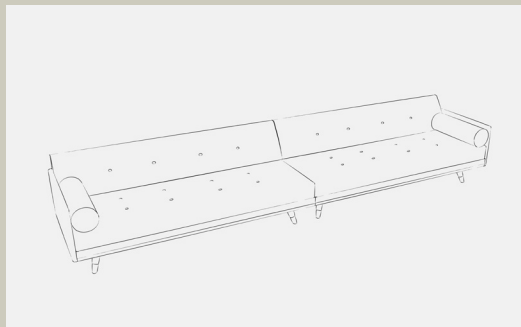



No. 6 Series

An evolution of No. 5. Designed and built with exquisite attention to detail. Four core seating designs which work as standalone pieces or can be strung together in infinite configurations.

Standard species: White Oak
Finishes: Kalon Bare Finish
Standard Fabrics: Wool

Custom dimensions, species and COM available upon request.
Estimated lead times and shipment: 8 - 12 weeks

No. 6 Series

The collection includes a chaise, chair, sofa and sectional.

502-SF



502-CHR



502-SE

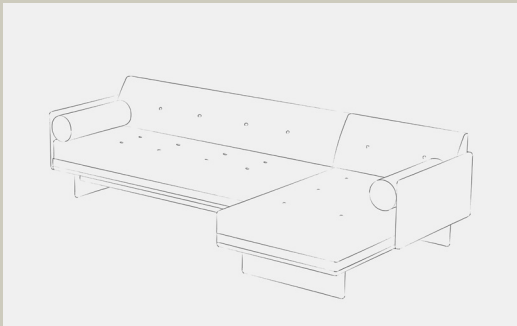

502-CHS

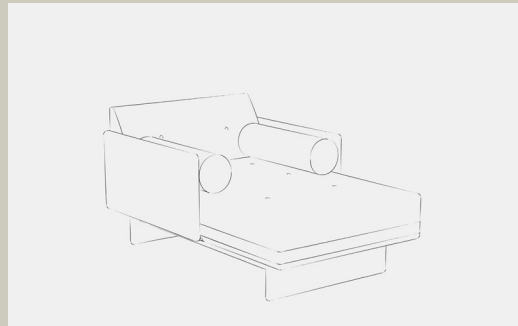



Caravan Collection

An iconic and timeless collection evoking balance and ease for nursery and beyond. A exploration of archetypal form. Pared-back simplicity that integrates with all styles.

Standard species: Ash / White Oak / Walnut
Finishes: Kalon Bare Finish or Natural Oil/Wax

For select items, custom dimensions, finishes and species available upon request.

Estimated lead times and shipment: Inventory

Caravan Collection

The collection includes a convertible crib, dresser, double dresser, divan, conversion kit, changing tray and organic crib mattress.

O41-RAW
O41-O



O41-OAK



O41-WAL



O42



O43-OAK



O43-WAL



O43-RAW
O43-O



143



Standard species: Ash / White Oak / Walnut
Finishes: Kalon Bare Finish or Natural Oil/Wax

For select items, custom dimensions, finishes and species available upon request.

Estimated lead times and shipment: 6-8 weeks

Caravan Collection

The collection includes a convertible crib, dresser, double dresser, divan, conversion kit, changing tray and organic crib mattress.

045-O



045-OAK



045-WAL



046-O



046-OAK



046-WAL



044-M



001-N





Echo Collection

Immersive materiality and sculptural form. A cocoon-like, convertible crib of singular beauty crafted for the nursery from natural, non-toxic materials.

Echo Collection

Standard species: Ash
Finishes: Kalon Bare Finish

Estimated lead times and shipment: 8-10 weeks

The collection includes two convertible cribs and a changing tray.

021-O



021-W



021-O



021-O



044-M





Io Collection

The dynamism of negative space. A crib design that breaks from all traditions, with an ornate geometry inspired by Moroccan screens and Frank Lloyd Wright's stained glass panels.

Io Collection

Standard species: White Oak
Finishes: Kalon Bare Finish

Estimated lead times and shipment: Inventory

The collection includes a convertible crib, and a changing tray.

011-OAK



011-OAK



011-OAK



044-O





Stump & Trunk Collection

A playful juxtaposition of rawness and precision, with endless uses. A celebration of the living materiality of wood, felled in the forests of Maine.

Standard species: Ash or Maple (Green Wood)
Finishes: Raw (Unfinished)

Custom dimensions, species and finishes available upon request.
Estimated lead times and shipment: 1-3 weeks

Stump & Trunk Collection

The collection includes stumps and trunks in various sizes.

141-S



141-L



142-S



142-L
142-L-60



141-A



141-LE



141-C



141-W





Tableware Collection

Elegantly utilitarian tableware with uncompromisingly perfected forms. Made by craftspeople in Bosnia, where wood-carved tableware is recognized by UNESCO as part of humanity's intangible cultural heritage.

Standard species: Natural / Roasted Maple
Finishes: Natural Oil/Wax

Estimated lead times and shipment: TBD

Tableware Collection

The collection includes an 8.5" plate, 11" plate, 6" bowl, 8" bowl, 14" bowl, cup and platter.

410-M-8.5-P
410-W-8.5-P



410-M-11-P
410-W-11-P



410-M-6-B



410-W-6-B
410-W-6-B-L



410-M-8-B



410-M-8-B
410-W-8-B-L



410-M-14-B
410-W-14-B



410-W-14-B-L



Standard species: Natural / Roasted Maple
Finishes: Natural Oil/Wax

Estimated lead times and shipment: TBD

Tableware Collection

The collection includes an 8.5" plate, 11" plate, 6" bowl, 8" bowl, 14" bowl, cup and platter.

410-M-PLAT



410-W-PLAT



401-FS-M

401-FS-W



410-M-C

410-W-C



Beyond Beauty

Kalon (pronounced like ‘Talon’ but with a ‘K’) is an ancient, philosophical concept of ideal beauty that considers moral worth and usefulness as inextricable from aesthetics. When an object is kalon, it is beautiful because there is an inherent goodness that radiates from each detail. The truly beautiful is one and the same with the truly good.

Kalon Studios was founded not only to create products that stimulate and inspire, but to use design for positive change. It’s an inherently optimistic mission, and achieving it is no small feat. For us, it’s the seed of inspiration for every decision we make.



The ways we work

Our Design Commitments — Beyond Human-Centered Design

The decisions we make have an ecosystem of impact that reverberates far beyond the acts of ideation and creation, and every choice is a chance to support something — or not support something. By knowing this, we can design with intention, and activate the political, social, and cultural aspects of our respective practices. This means that from design to production, each piece must be functional, long-lasting, and of the highest quality. Along the way, it must support local communities, uphold craft traditions, and reimagine how we all engage with material goods.

Producing with intention

We don't design to industry standards, we design and develop beyond them. Our pieces and materials meet some of the world's most stringent sustainability standards, but more importantly, they meet our standards. The materials we work with are carefully selected for their unique qualities as well as their ability to grow more beautiful with age and use. This is no accident — the longer we love a piece, the more sustainable that purchase becomes. To that end, pieces are designed with flexibility of use, durability, and timeless appeal in mind. Rather than planned obsolescence, we design with planned longevity in mind. Our hope is that our work will adapt to our customers' ever-changing needs and tastes over the course of a lifetime. We choose to work with natural materials to ensure end-of-life bio-availability of our designs. We use safe, non-toxic materials that don't emit harmful VOCs or odors.

Championing local craft

As we work to find sustainable solutions to manufacturing, we engage many of the newest — and sometimes, the oldest — methods and materials. Our intent is to sustain and revitalize the businesses, communities and craft traditions most local to us. By choosing to work with small-scale, often family-owned FSC-certified manufacturers and small teams of highly skilled craftspeople, we are keeping vital economic diversity, jobs, and skills in our communities. By bringing our approach to these manufacturers, we expand the industrial commons while amplifying our impact.

Minding our impact

We follow a philosophy of local manufacturing, harvesting lumber from the forests most local to where our pieces are made. Sustainable forestry practices, centering on domestic hardwoods, ensure that forests managed for the production of wood products contribute to healthy ecosystems. We use a Batch Size One production model, where it is as efficient and cost effective to produce a single item as it is to produce a run of 1,000. In this way, we break from the destructive cycles of mass production, overconsumption of resources, and wasteful overproduction. Additionally, every Kalon piece meets an extremely high standard of 90% material efficiency or more. Despite this already industry-leading example, we are continually redeveloping our manufacturing process to create less waste.