



Material Studies — Rugosa



Material Studies Rugosa Chair, Side Table and Dining Table - Oxblood & Limewhite



Material Studies Rugosa Chair - Oxblood & Clay



Material Studies Rugosa Side Table and Chair - Oxblood



Material Studies Rugosa Side Table - Limewhite





## Kalon

---

Stemming from a belief in the beauty and emotive power of everyday objects, Kalon seeks to deepen our relationship and reverence for the things we live with. Kalon's work maintains a strong point of view informed by American furniture traditions and modernist design, with a focus on elemental forms, natural materials, and versatility. The studio prides itself on its intense attention to materiality, which is at the core of each design. With a commitment to ecologically-conscious, regional production, Kalon partners with small teams of highly skilled, fairly paid craftspeople and uses the highest quality, locally sourced natural materials and finishes. By balancing traditional craft modalities with high-tech precision manufacturing and modern forms, Kalon invites a new chapter of contemporary, sustainable design. Kalon was founded in 2007 by Michael Simmering and Johannes Pauwen and is based out of Los Angeles, California.

## Material Studies — Rugosa

---

Released in 2020 in sustainably harvested Western Sugar Pine wood and as a decidedly indoor collection, the Rugosa Collection is the synthesis of a many years' conversation exploring the evolving function and spirit of the living room. With this first chapter in our Material Studies, the translation of the Rugosa collection into metal explores the profound impact material choice has on design and, practically speaking, allows Rugosa to move outdoors. The rich, reflective hues of powder-coated aluminum bring a flash of color and vibrancy to an outdoor setting, and the indoor-outdoor nature of the work plays with perceptions of our living environments. This series deepens our studio's interests in the cultural history of material use.

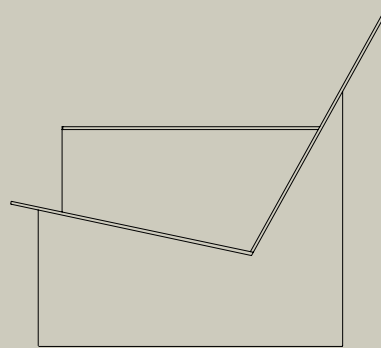
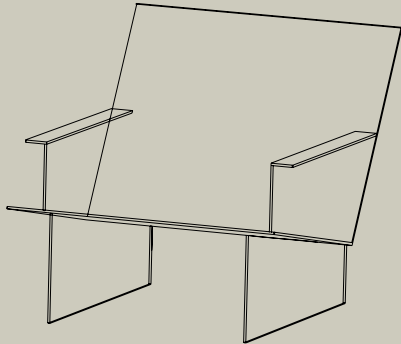

## The Material Studies Rugosa Chair

**DIMENSIONS**

33" L x 31" W x 29" H

**ORIGIN**

Made in California

**MATERIALS**

Aluminum

Trevira

Trillium Fill

**COLOR OPTIONS**



Oxblood

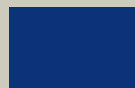

Lapis

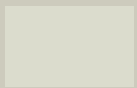

Lime White

**UPHOLSTERY OPTIONS**

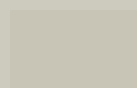

Clay



Carmine

The Material Studies Rugosa Chair is an indoor-outdoor chair made from powder-coated aluminum and GreenGuard Certified, outdoor-rated textiles with Trillium fill. A vibrant palette, including oxblood, lapis and lime white, both celebrates and contrasts the textures and hues of the landscape. Appropriate for residential and commercial spaces and able to withstand both seaside and desert conditions. Highly-durable and resistant to rust and corrosion.

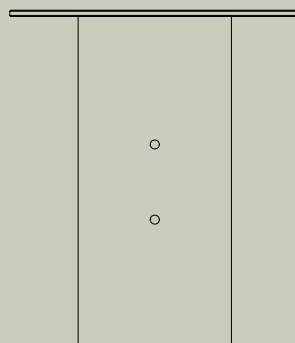
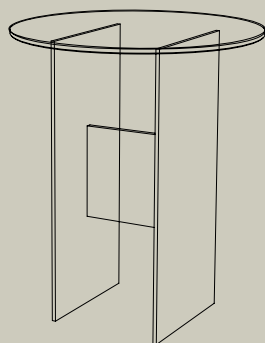

## The Material Studies Rugosa Side Table

### DIMENSIONS

18" L x 18" W x 19.8" H

### ORIGIN

Made in California

### MATERIALS

Aluminum

Bronzed Glass

Able to furnish an indoor or outdoor setting, the Material Studies Rugosa Side Table is made of powder-coated aluminum and bronzed glass. The elegant, minimal silhouette in a vibrant painted-metal palette, nods to the utilitarian and industrial as much as it does to the sophisticated and playful. Highly resistant to rust and corrosion and highly-durable, it is able to withstand both seaside and desert conditions.

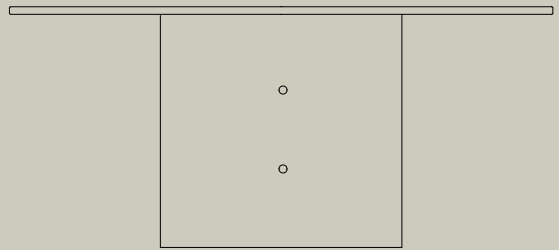
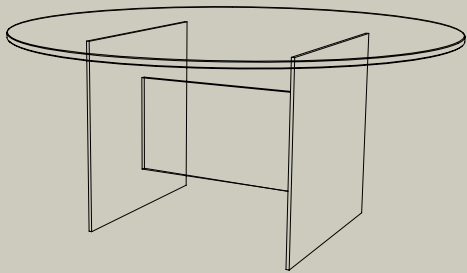

## The Material Studies Rugosa Coffee Table

### DIMENSIONS

36" L x 36" W x 16" H

### ORIGIN

Made in California

### MATERIALS

Aluminum  
Bronzed Glass

Able to furnish an indoor or outdoor setting, the Material Studies Rugosa Coffee Table is made of powder-coated aluminum and bronzed glass. The elegant, minimal silhouette in a vibrant painted-metal palette, nods to the utilitarian and industrial as much as it does to the sophisticated and playful. Highly resistant to rust and corrosion and highly-durable, it is able to withstand both seaside and desert conditions.

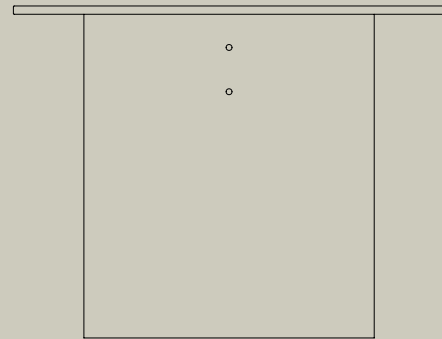
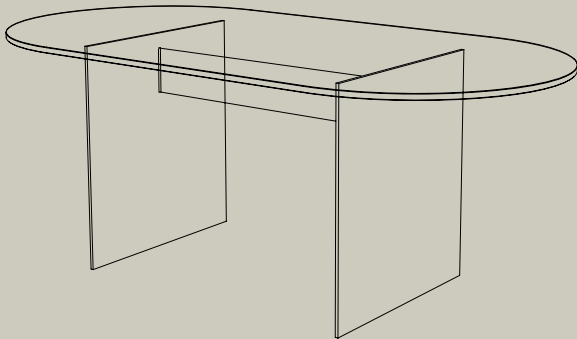

## The Material Studies Rugosa Dining Table

### DIMENSIONS

78" L x 18" W x 30" H

### ORIGIN

Made in California

### MATERIALS

Aluminum  
Bronzed Glass

Able to furnish an indoor or outdoor setting, the Material Studies Rugosa Dining Table is made of vibrant, powder-coated aluminum and bronzed glass. Equally at home in interior spaces, this piece exudes a joyful sophistication. Appropriate for residential and commercial spaces and able to withstand both seaside and desert conditions. Highly-durable and resistant to rust and corrosion.

Standard materials: Aluminum  
Finishes: Oxblood, Lapis, Lime White  
Standard Fabrics: Trevira  
Other Materials: Bronzed Glass

Custom dimensions, species and COM available upon request.  
Estimated lead times and shipment: 8-10 weeks

# The Material Studies Collection

The collection includes an armchair, side table, coffee table and dining table.

512-A



514-A



513-A



517-A



## Beyond Beauty

---

Kalon (pronounced like ‘Talon’ but with a ‘K’) is an ancient, philosophical concept of ideal beauty that considers moral worth and usefulness as inextricable from aesthetics. When an object is kalon, it is beautiful because there is an inherent goodness that radiates from each detail. The truly beautiful is one and the same with the truly good.

Kalon Studios was founded not only to create products that stimulate and inspire, but to use design for positive change. It’s an inherently optimistic mission, and achieving it is no small feat. For us, it’s the seed of inspiration for every decision we make.



## The ways we work

---

### **Our Design Commitments — Beyond Human-Centered Design**

The decisions we make have an ecosystem of impact that reverberates far beyond the acts of ideation and creation, and every choice is a chance to support something — or not support something. By knowing this, we can design with intention, and activate the political, social, and cultural aspects of our respective practices. This means that from design to production, each piece must be functional, long-lasting, and of the highest quality. Along the way, it must support local communities, uphold craft traditions, and reimagine how we all engage with material goods.

### *Producing with intention*

We don't design to industry standards, we design and develop beyond them. Our pieces and materials meet some of the world's most stringent sustainability standards, but more importantly, they meet our standards. The materials we work with are carefully selected for their unique qualities as well as their ability to grow more beautiful with age and use. This is no accident — the longer we love a piece, the more sustainable that purchase becomes. To that end, pieces are designed with flexibility of use, durability, and timeless appeal in mind. Rather than planned obsolescence, we design with planned longevity in mind. Our hope is that our work will adapt to our customers' ever-changing needs and tastes over the course of a lifetime. We choose to work with natural materials to ensure end-of-life bioavailability of our designs. We use safe, non-toxic materials that don't emit harmful VOCs or odors.

*Championing local craft*

As we work to find sustainable solutions to manufacturing, we engage many of the newest — and sometimes, the oldest — methods and materials. Our intent is to sustain and revitalize the businesses, communities and craft traditions most local to us. By choosing to work with small-scale, often family-owned FSC-certified manufacturers and small teams of highly skilled craftspeople, we are keeping vital economic diversity, jobs, and skills in our communities. By bringing our approach to these manufacturers, we expand the industrial commons while amplifying our impact.

*Minding our impact*

We follow a philosophy of local manufacturing, harvesting lumber from the forests most local to where our pieces are made. Sustainable forestry practices, centering on domestic hardwoods, ensure that forests managed for the production of wood products contribute to healthy ecosystems. We use a Batch Size One production model, where it is as efficient and cost effective to produce a single item as it is to produce a run of 1,000. In this way, we break from the destructive cycles of mass production, overconsumption of resources, and wasteful overproduction. Additionally, every Kalon piece meets an extremely high standard of 90% material efficiency or more. Despite this already industry-leading example, we are continually redeveloping our manufacturing process to create less waste.